



General Packet Radio Service (GPRS)

OVERVIEW

Payment Express provides users with the ability to process transactions wirelessly via a secure, private GPRS network. The Payment Express GPRS system processes transactions securely from a wide variety of applications and platforms and can be used for both EFTPOS and card holder not present transactions.

GPRS is currently available in Australia and New Zealand only. Communication is done securely via a private APN setup with Vodafone. This communication channel, coupled with the use of the secure payment components, make this the ideal solution for businesses wanting either a primary connection for wireless applications or a redundant internet service to the Payment Express transaction host.

DPS use and recommend the Telit EZ-10 GPRS Modem.

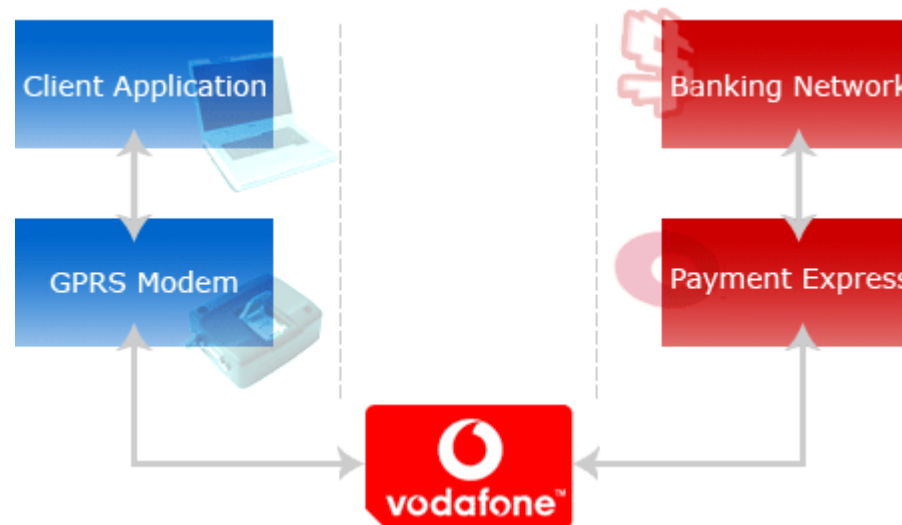

APPLICATION

Secondary/Backup Connection

How much downtime can your business afford? What can you do when your broadband internet connection is unavailable?

Apart from relying on Electronic Offline Voucher (EOV) Mode, the answer to these questions is usually “none” and “nothing”.

This is why many of our EFTPOS merchants use GPRS as a secondary backup connection for their EFTPOS system. GPRS accommodates for times when the merchant is experiencing difficulties with their fixed line internet access.

GPRS modems are standalone units which connect to the POS machine via the serial port or USB port. Since these units act independently from your existing local area network (LAN) setup, if the merchant experiences any LAN issues, phone line issues, or hardware issues, the GPRS modem will still be available.

If internet connection drops, DPS EFTPOS software will route transactions to GPRS in around 30 seconds. Please note that any transactions processed during the time internet drops or GPRS has not kicked in, the transaction will timeout. Once your primary internet connection is back online, DPS EFTPOS software will route via primary connection. This is usually within 30 seconds also. Please note time quoted can vary from PC to PC depending on specifications.

Primary Connection

Depending on where your business is located, fixed line internet access may not be available. GPRS can be used basically anywhere a mobile phone can receive signal. This allows merchants in remote or unique locations to accept EFTPOS transactions.

Mobile Connection

Businesses on the move benefit greatly from a GPRS connection. The merchant can take their business anywhere (within GPRS coverage) and still process EFTPOS transactions. This is particularly useful for taking your POS and EFTPOS solution to trade shows and exhibitions.

GPRS MODEM

Telit EZ-10 GPRS Modem package contents

- Telit EZ-10 unit
- Vodafone SIM card
- Aerial
- Serial connection cable
- BAFO – Serial to USB convertor (optional)
- USB connection cable (optional)
- Power pack & cable

Dimensions

- Housing Length: 83 mm (without connectors)
- Overall Length: 107 mm (including fixtures)
- Width: 64 mm
- Thickness: 33 mm
- Weight: 150 grams

The Telit EZ10 wireless modem can be fixed on a suitable surface by two screws through the holes (3,3 / 5,8 mm diam.) in the lids forming part of the front and rear panels. In case of a permanent vertical installation in dusty environment, it is recommended to cover the SIM slot with a self-adhesive tape.

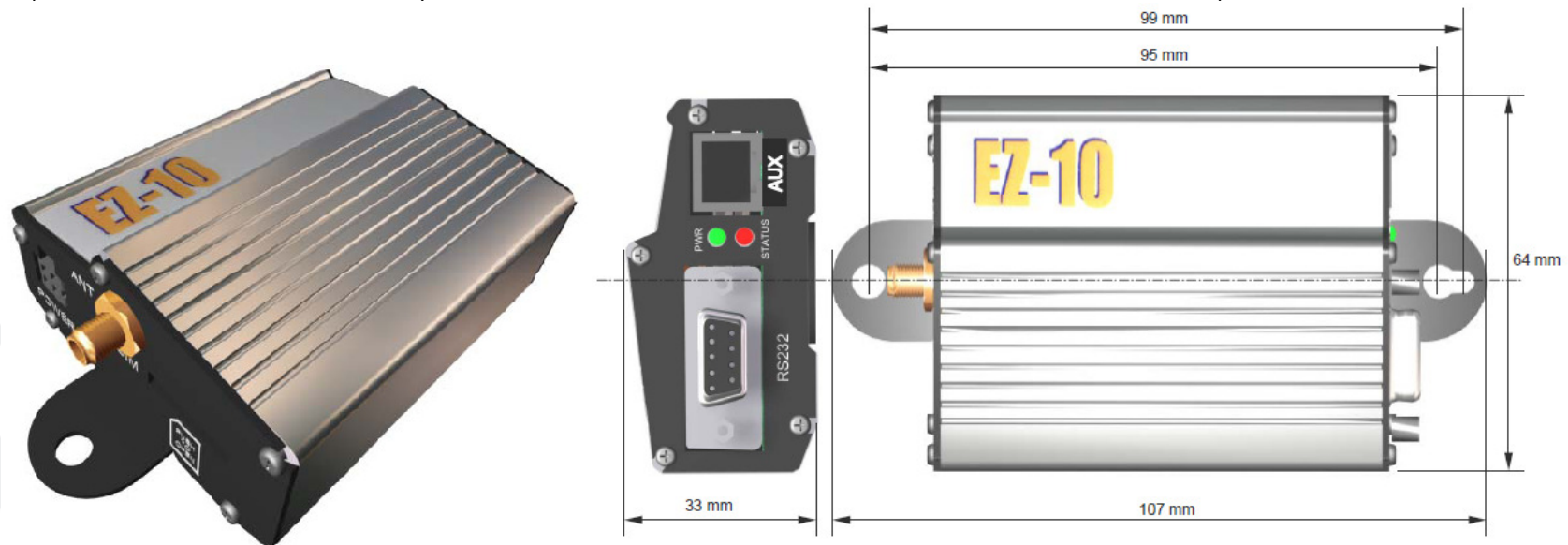

The modem has two indicator lights, the green light indicates power only and will stay solid when unit is powered on. The red indicator light alternates off and on to indicate its status. When searching for a network/carrier the light will flicker every half second. Once connected the light will flicker every 2-3 seconds.

All GPRS modems will be configured and tested by DPS prior to shipping.

GPRS SETUP TYPES

There are 3 types of GPRS setups.

Single Lane Backup

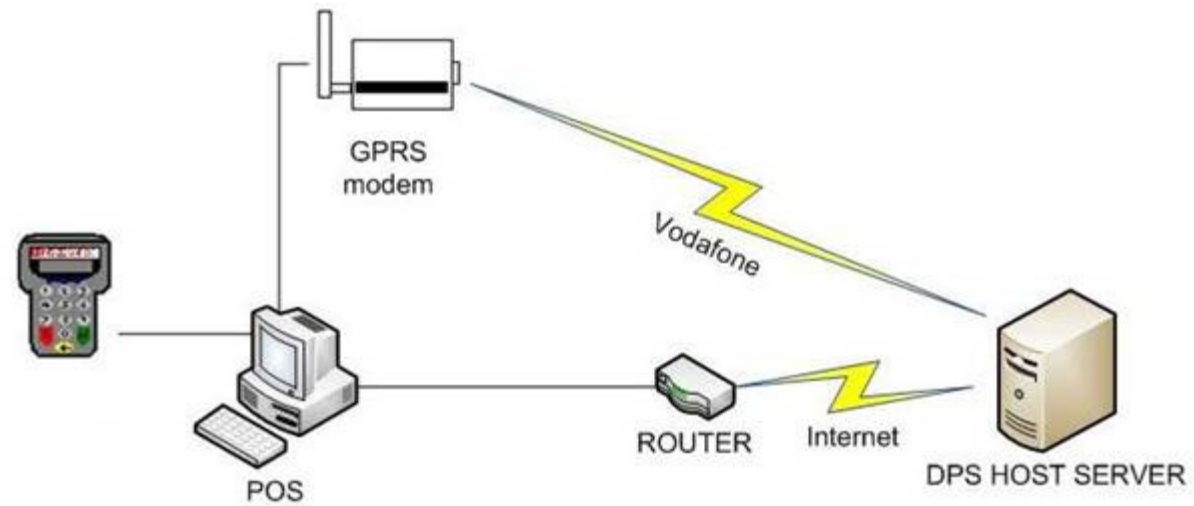

Single Lane setup consists of one DPS PINpad, one POS PC, and one GPRS modem connected to the POS PC. This is the simplest of setups and DPS software simply looks for the GPRS modem/connection on one of the local COM ports.

Multi-Lane shared GPRS

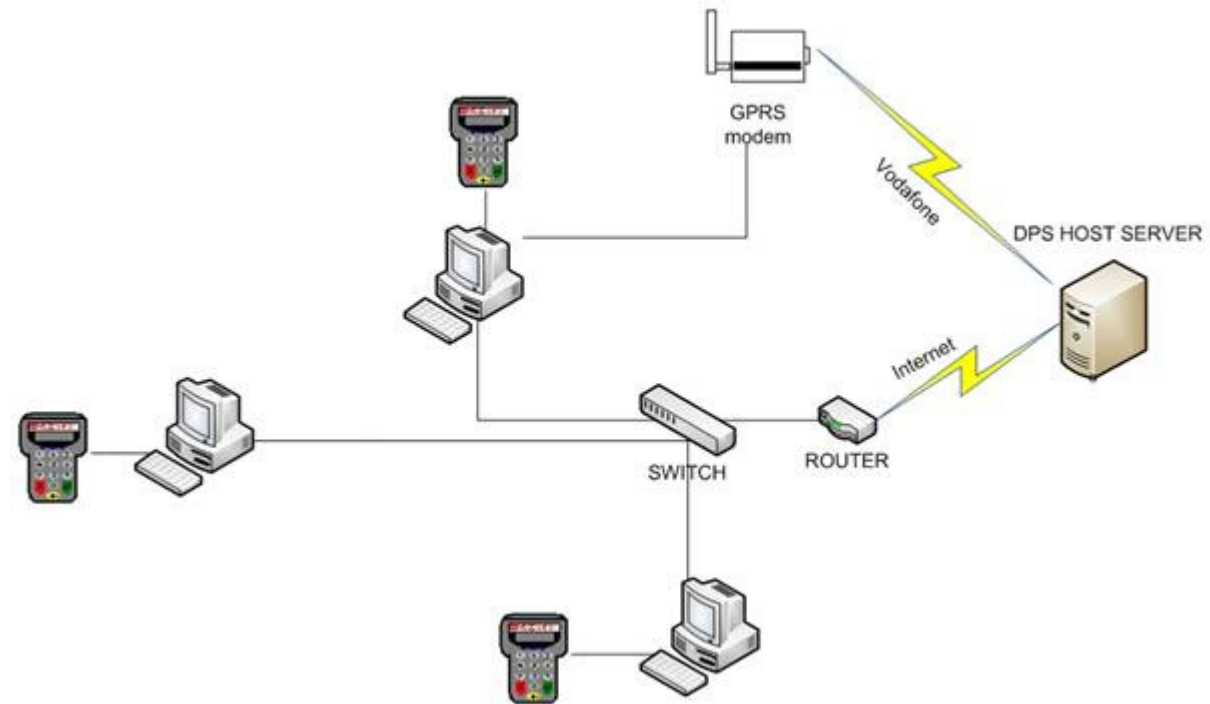

Multi-Lane GPRS consists of multiple PINpads and POS PC's setup in a local network. One PINpad and POS PC is nominated to be the "Master". This Master PC will have the GPRS modem connected.

All others are "Listeners". DPS software on Listener PC's will look for a GPRS modem/connection via the Master PC. This means that the Master PC IP address needs to be setup manually in DPS configurations for all Listeners.

Backoffice GPRS

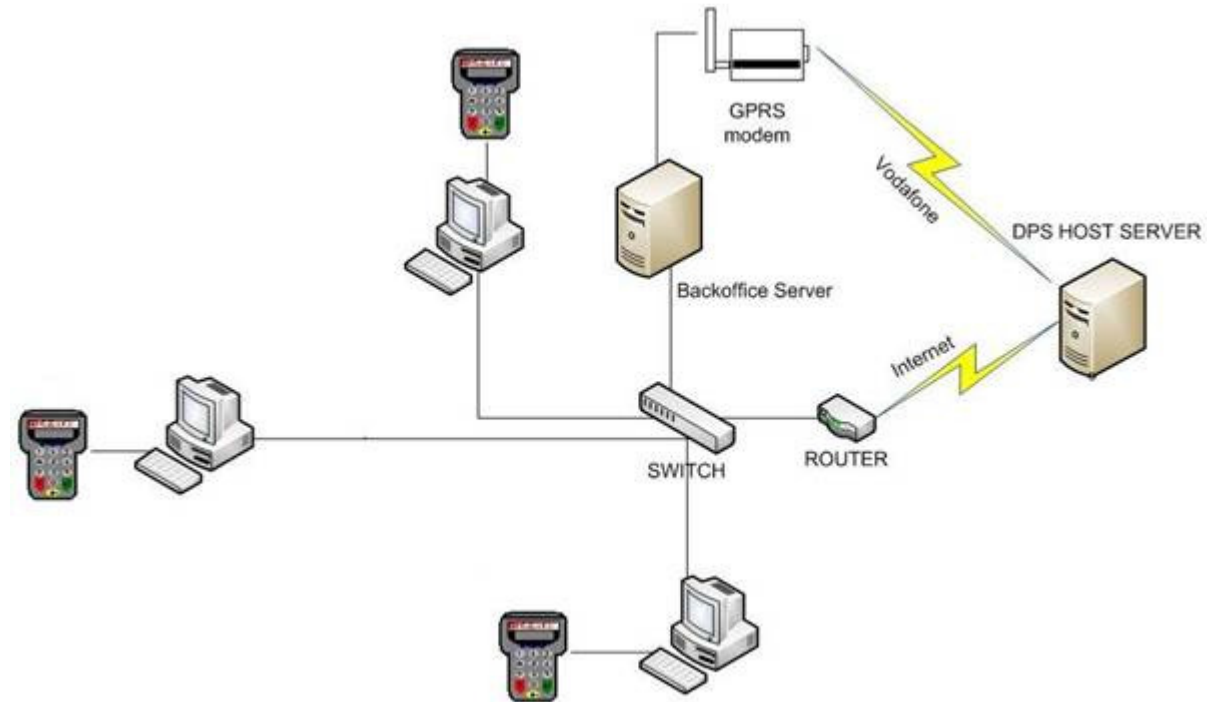

Backoffice is similar to Multi-Lane, however instead of nominating a POS PC, the GPRS modem is connected to a backoffice server. All POS PC's are "Listeners".

DPS Software on Listener PC's will look a GPRS modem/connection via the server PC. This means that the server PC IP address needs to be setup manually in DPS configurations for all Listeners. Since the standard EFTPOS software is not required on the server PC (because there is no PINpad), only specific components such as communication service and configuration files need to be installed on the server.

PREPARATION

Please consider the following factors when implementing a GPRS connection. These factors need to be passed onto DPS prior to installing GPRS.

Primary or Secondary

Decide whether the GPRS unit will be used as the main connection or backup connection.

Select a GPRS setup type (Single Lane, Multi-Lane, Backoffice)

All GPRS setups need to be configured at DPS prior to installation. Please make sure a setup type is selected and passed onto our Sales team.

IP Address

If either backoffice or multi-lane is selected, the IP address of the master PC (multi-lane) or server PC (backoffice) will need to be supplied.

Connectivity

All listeners must be able to communicate with the master PC (multi-lane) or server PC (backoffice). Please make sure all listeners can successfully ping the master/server pc.

USB or Serial port availability

One free USB or Serial port is required for the GPRS modem. When requesting for a GPRS modem please ensure that the appropriate cable (Serial/USB) is requested.

Privileges

Administrative privileges are required to install the GPRS Service.

INSTALLATION

Installation procedure below works for both new and existing DPS EFTPOS setups provided.

Note: Even for existing setups, reinstallation is the easiest and preferred method of GPRS installation. If a reinstallation is not suitable, GPRS can be installed and configured manually. Please inform DPS during initial GPRS request if the manual method is preferred.

Single-Lane Installation

- Connect GPRS modem to PC and power on the unit.
- Browse to www.paymentexpress.com to download the relevant EFTPOS installer.
- Run the installer and plug the PINpad into the PC when prompted.
- Once initialized, the installer will pick up the PINpad and the installation will continue downloading all required components.
- EFTPOS and GPRS are now installed.

Multi-Lane Installation

- Connect GPRS modem to Master PC and power on the unit.
- Browse to www.paymentexpress.com to download the relevant EFTPOS installer.
- On all PC's (Listeners and Master), run the installer and plug the PINpad into the PC when prompted.
- Once initialized, the installer will pick up the PINpad and the installation will continue downloading all required components.
- EFTPOS and GPRS are now installed.

Backoffice Installation

- Browse to www.paymentexpress.com to download the relevant EFTPOS installer.
- On all Listener PC's, run the installer and plug the PINpad into the PC when prompted.
- Once initialized, the installer will pick up the PINpad and the installation will continue downloading all required components. EFTPOS is now installed.
- Connect GPRS modem into Server PC and power on the unit.
- Download the "telitinstall.zip" from <https://www.paymentexpress.com/eftpos/telitinstall.zip> to your backoffice server.
- Extract files to C:\Program Files\DPS\Eftpos.
- Run install.bat to install the master communication service (PaymentExpressPxEftPS).
- Open pxeftpMS_cfg.txt.
- Populate the "Address" property with the IP address of the server e.g. <Address>192.168.1.200</Address>.
- Populate the "PortNum" property with the com port number that the GPRS modem is plugged into e.g. <PortNum>1</PortNum> for COM1.
- Save pxeftpMS_cfg.txt.
- Restart the PaymentExpressPxEftPS service.
- GPRS is now installed.

STATUS CHECK

A good place to check the status of your GPRS connection is the 'EFTPOS Status Details' window. This can be accessed by right clicking the DPS tray icon and selecting 'Status Details'. All available interfaces will be listed in the Interfaces box.

In the example to the right, both EFT1 and GPRS connections are online (indicated by a green square).

- EFTPOS will be routed to EFT1 when both EFT1 and GPRS are green.
- EFTPOS will route to GPRS when EFT1 is red and GPRS is green.
- EFTPOS will be routed to EFT1 when EFT1 is green and GPRS is red.

This is all managed by priority settings in our configuration files.

When both connections are red i.e. fixed line internet and GPRS is not working, EFTPOS will attempt to go into EOV mode for offline transaction processing. Please note that all DPS terminals are setup to support EOV by default, however EOV needs to be setup with your merchant bank for EOV to work.

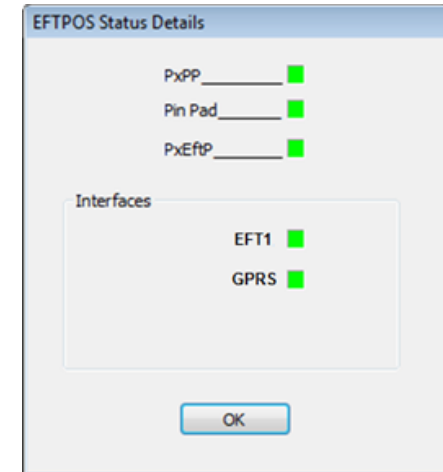

TESTING GPRS

The easiest method to test the GPRS connection is to disconnect the POS PC from the internet. If an internet connection is unavailable, EFTPOS will connect via GPRS.

This however may not be suitable in some environments and situations. The following section details how to test GPRS by manually editing the pxeftp_cfg.txt file.

- Open pxeftp_cfg.txt
- Under <Interfaces> you will find 1, 2 or 3 interfaces (a.k.a. connections). 2 example interfaces are shown below.

EFT1 – Primary Interface

```
<Interface>
<Id>1</Id>
<Name>EFT1</Name>
<Type>SCHANNEL</Type>
<Priority>3</Priority>
<Enabled>1</Enabled>
<Parameters>
<EnableHelloTimer>0</EnableHelloTimer>
<EnableSsl>1</EnableSsl>
<HelloTimerInterval>0</HelloTimerInterval>
<Address>eft1.paymentexpress.com</Address>
<Port>61</Port>
<DiscoverPort>0</DiscoverPort>
<DiscoverEnabled>0</DiscoverEnabled>
<DiscoverTimeout>0</DiscoverTimeout>
</Parameters>
</Interface>
```

GPRS – Backup Interface

```
<Interface>
<Id>2</Id>
<Name>GPRS</Name>
<Type>GPRS</Type>
<Priority>2</Priority>
<Enabled>1</Enabled>
<Parameters>
<EnableHelloTimer>0</EnableHelloTimer>
<EnableSsl>1</EnableSsl>
<HelloTimerInterval>0</HelloTimerInterval>
<Address>192.168.2.102</Address>
<Port>61</Port>
<APN>dps.co.nz</APN>
<DiscoverPort>0</DiscoverPort>
<DiscoverEnabled>0</DiscoverEnabled>
<DiscoverTimeout>0</DiscoverTimeout>
<EnablePortLocating>1</EnablePortLocating>
<PortNum>0</PortNum>
<ModemType>TELIT</ModemType>
</Parameters>
</Interface>
```

- In order to test GPRS, we need to disable the EFT1 interface on the left. This is the connection which uses the internet.
- To do this, change the value from 1 to 0 in the “Enabled” property i.e. <Enabled>1</Enabled> to <Enabled>0</Enabled>.
- Save changes.
- Restart PaymentExpressPxftP service

Since EFT1 is now disabled, the EFTPOS terminal will use GPRS instead. You can now test by doing a manual logon or transaction. A successful response will confirm that GPRS is working properly. This test is applicable for all types of GPRS setups. Once testing is complete, re-enable EFT1 by setting the “Enabled” property back to 1 and restarting the PaymentExpressPxftP service.